

## 9. 80x86 Mikroişlemci Ailesi İçin Çevre Birimleri

### 9.1. 8255 Paralel Giriş/Çıkış Birimi

#### 9.1.1. Uç Ayrıntıları

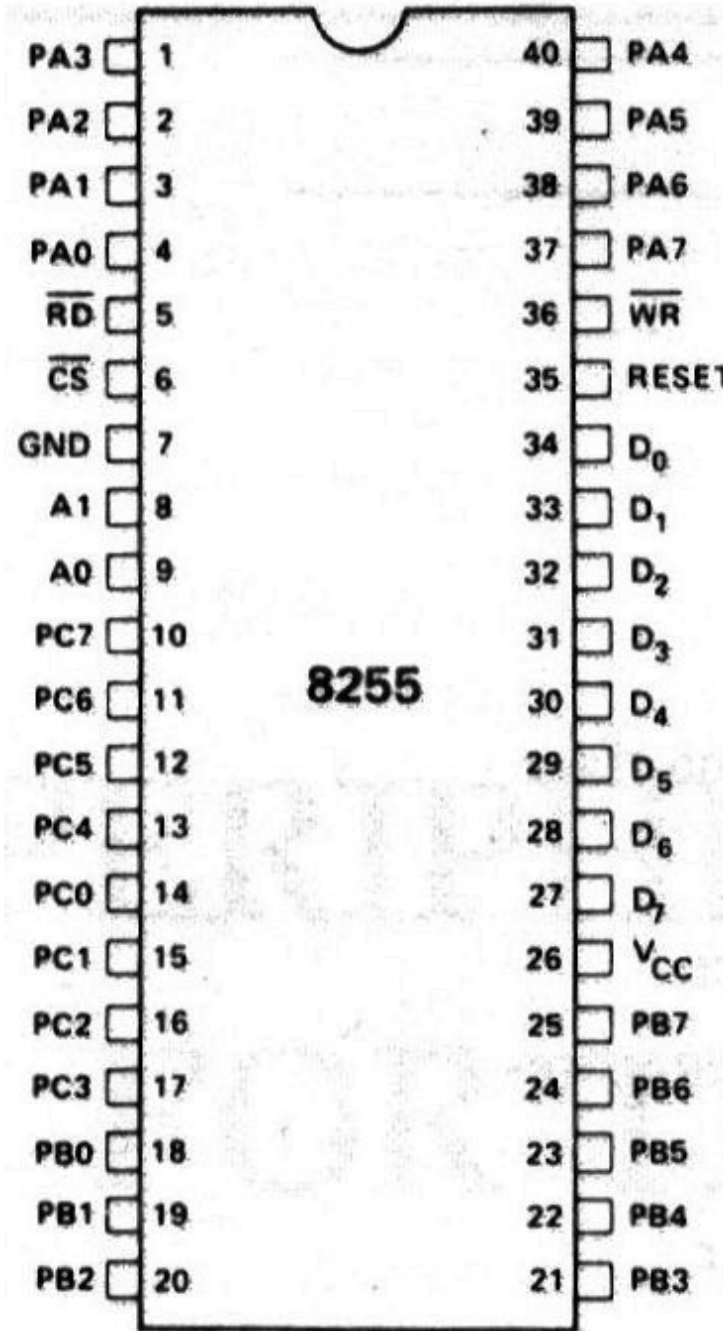

D0-D7	8-Bit Veri Yolu
A0,A1	İç yazmaç seçim
PA0-PA7	8-Bit G/Ç Port A
PB0-PB7	8-Bit G/Ç Port B
PC0-PC7	8-Bit G/Ç Port C
CS	Yonga Seçim
RD	Okuma
WR	Yazma
RESET	Yeniden başlat
VCC, GND	Besleme uçları

### 8255 Paralel Giriş/Çıkış Biriminin iç Blok Diyagramı

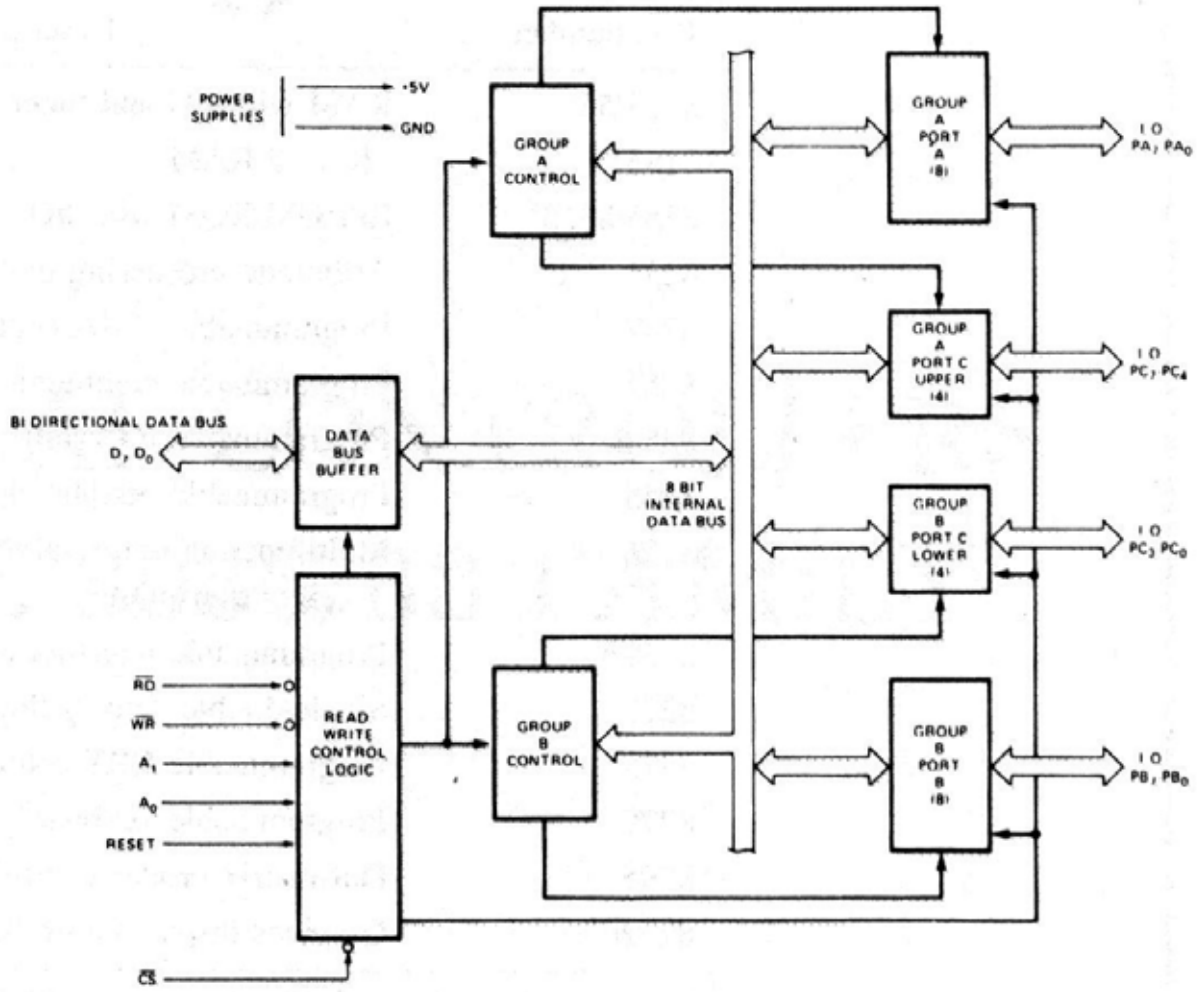

### 9.1.2. 8255 Paralel Giriş/Çıkış Birimi 8-Bit G/Ç Adres Çözümleme

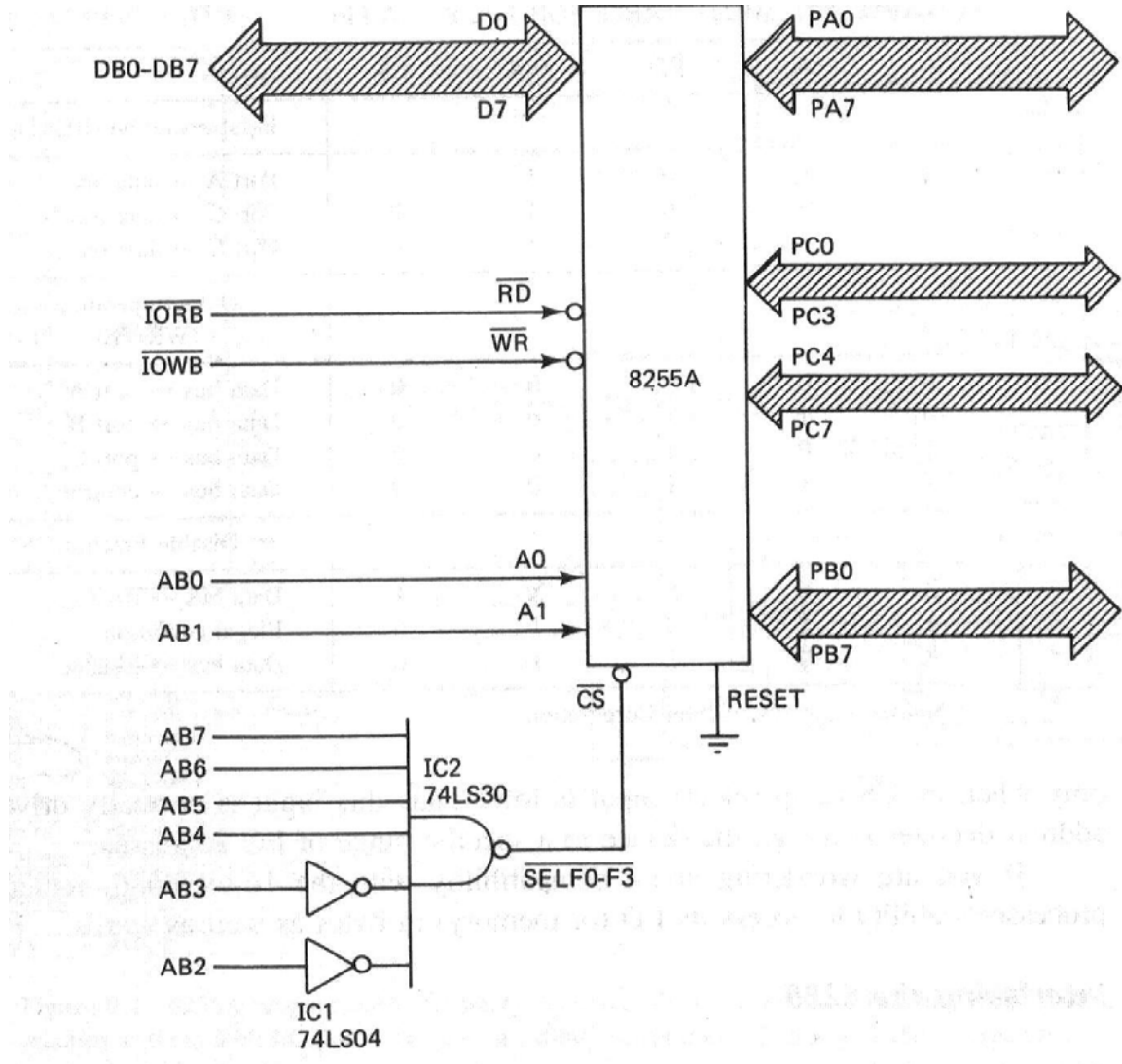

### 9.1.3. 8255 Paralel Giriş/Çıkış Birimi 16-Bit G/Ç Adres Çözümleme

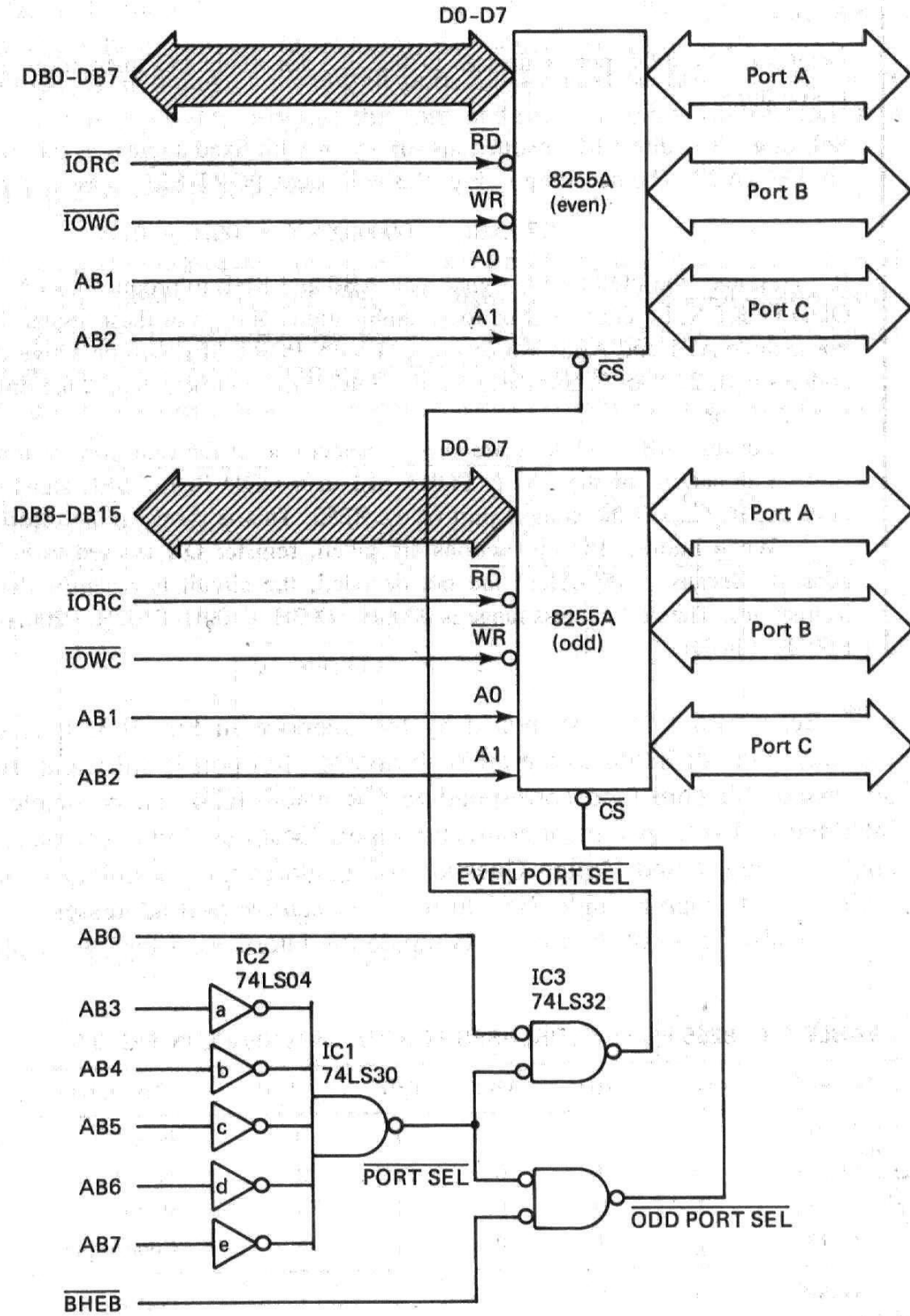

## 9.2. 8255 Paralel Giriş/Çıkış Birimi ile 2x8 Tuş Takımı Uygulaması

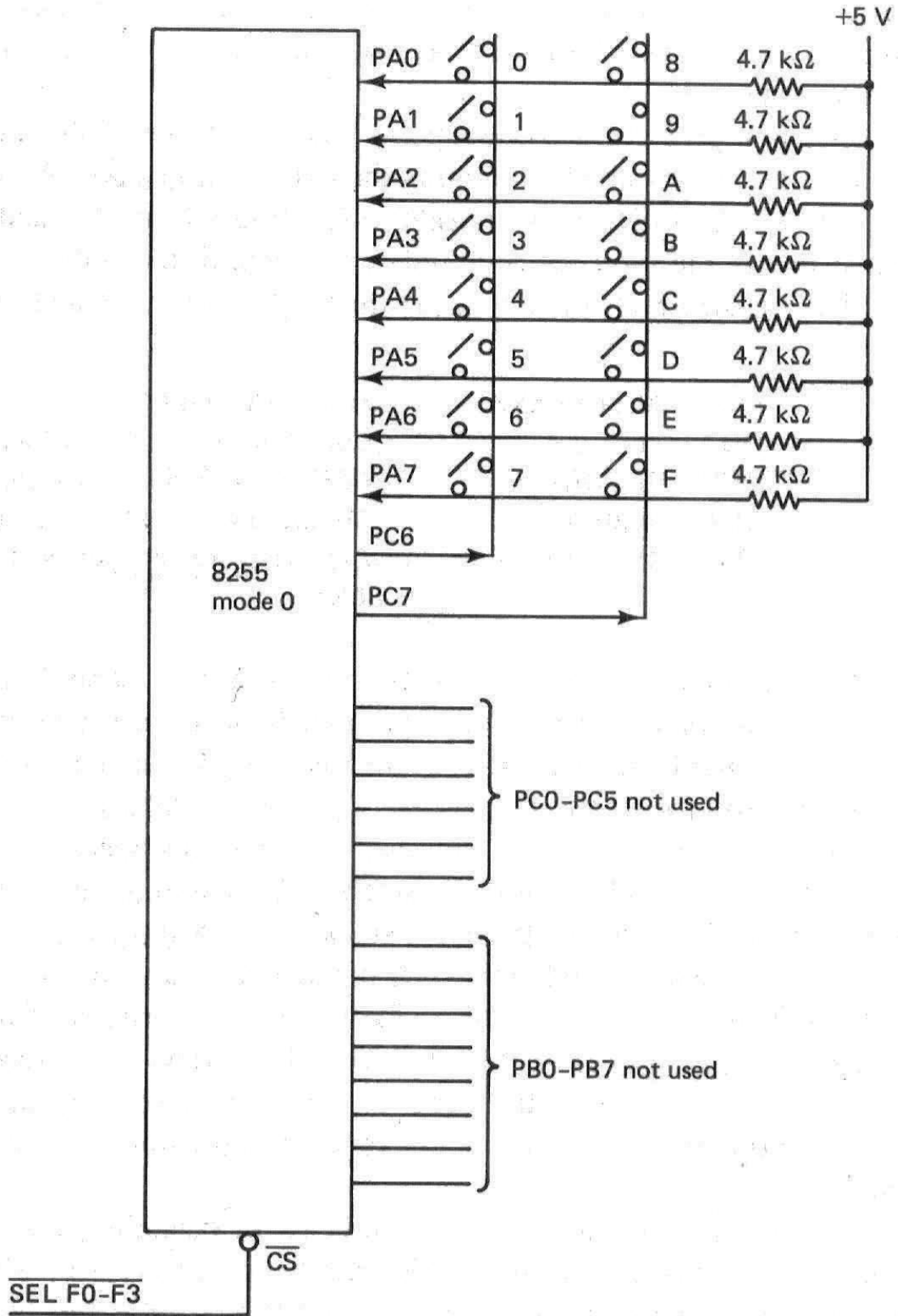

### 9.3. 8255 Paralel Giriş/Çıkış Birimi Mod 1 Çalışma Şekli

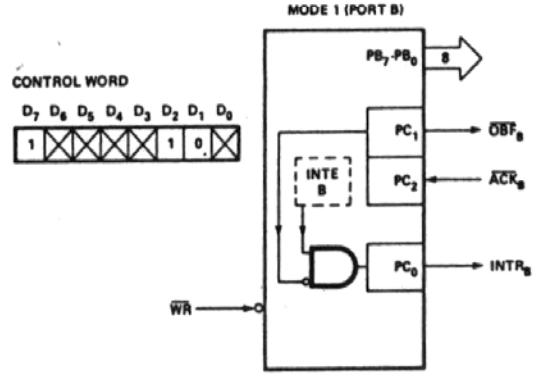
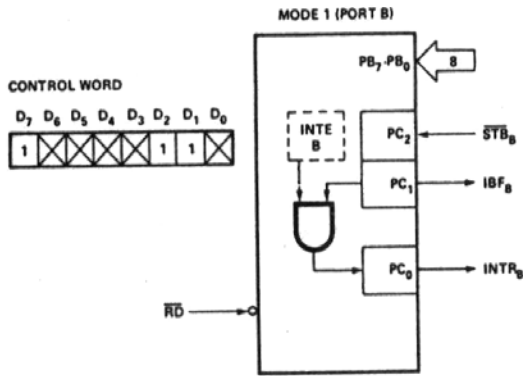
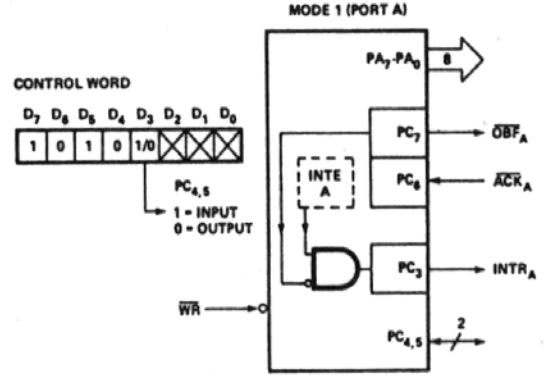
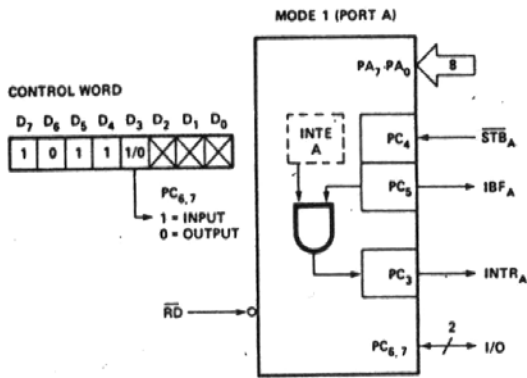

PORT A, B — (STROBED INPUT)

PORT A, B — (STROBED OUTPUT)

(a)

(b)

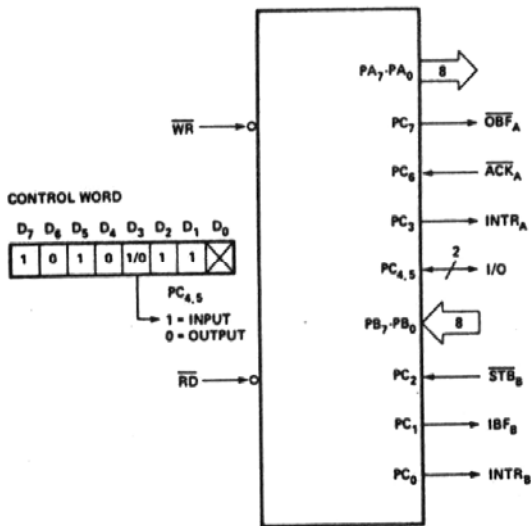

PORT A — (STROBED OUTPUT)  
 PORT B — (STROBED INPUT)

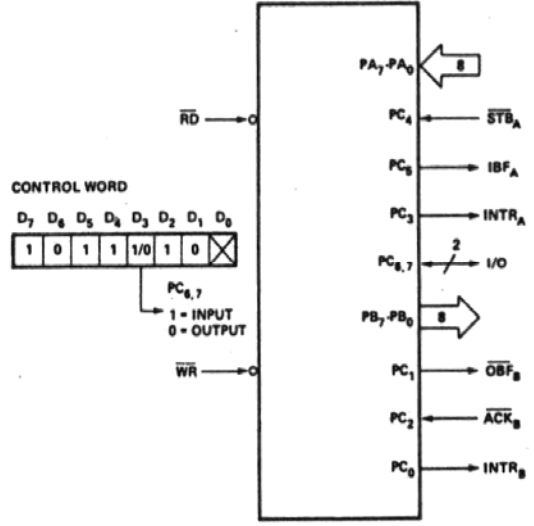

PORT A — (STROBED INPUT)  
 PORT B — (STROBED OUTPUT)

(c)

(d)

### 9.4. 8255 Paralel Giriş/Çıkış Birimi ile Yazıcı Uygulaması

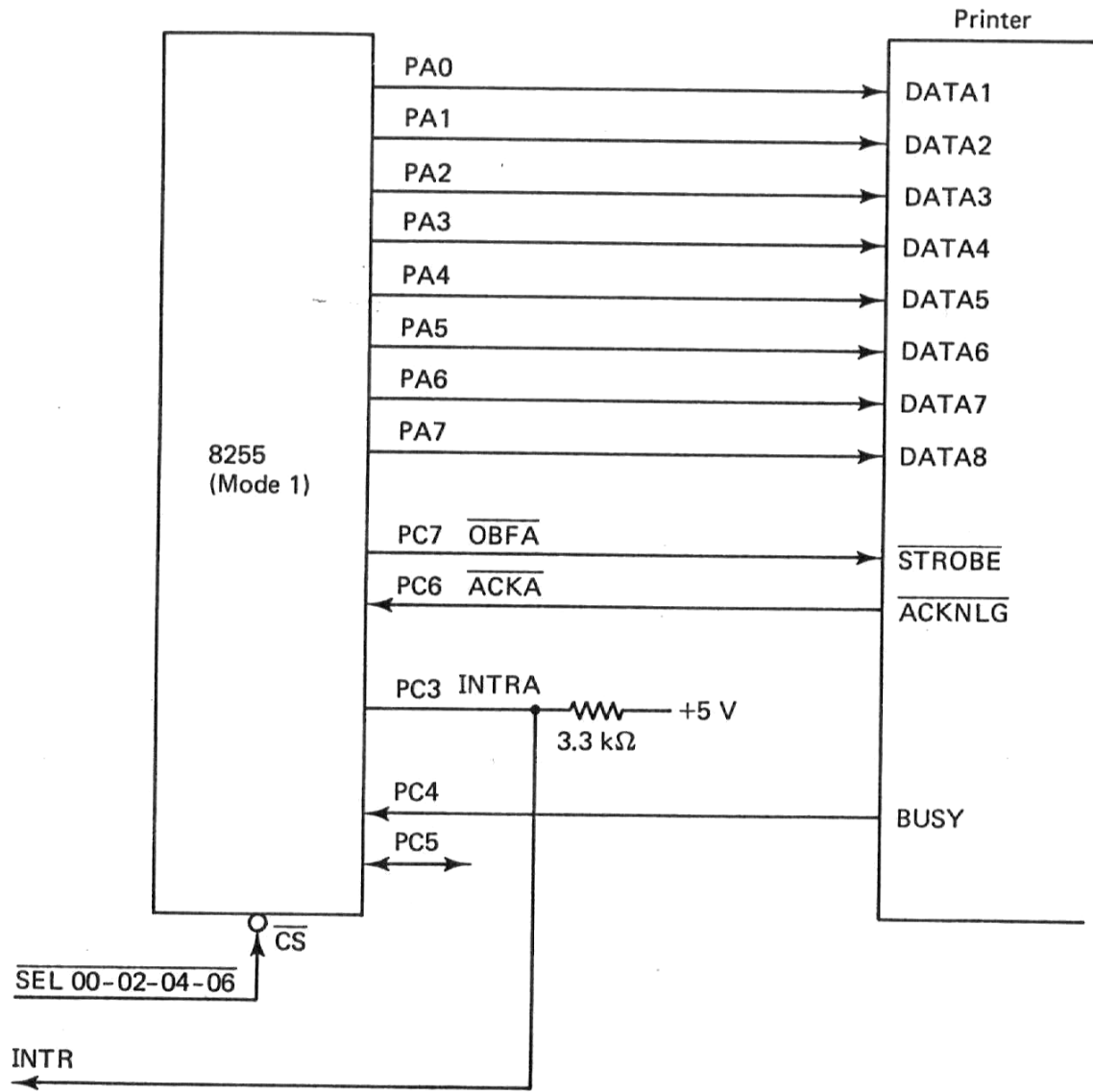

### 9.5. 8255 Paralel Giriş/Çıkış Birimi Mod 2 Çalışma Şekli

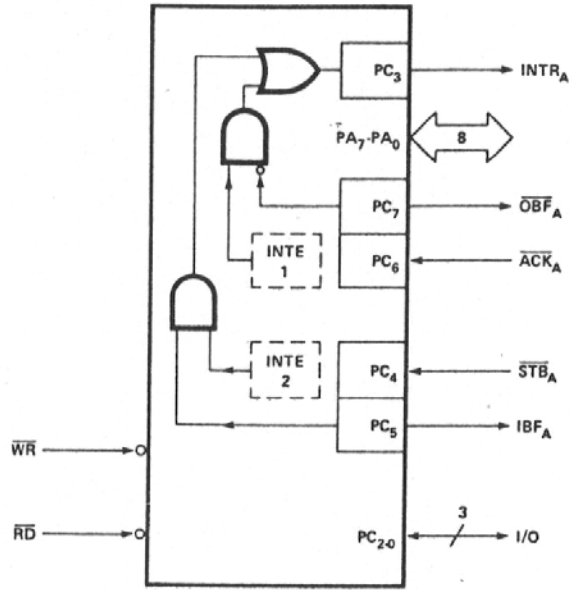



MODE 2 AND MODE 0 (INPUT)

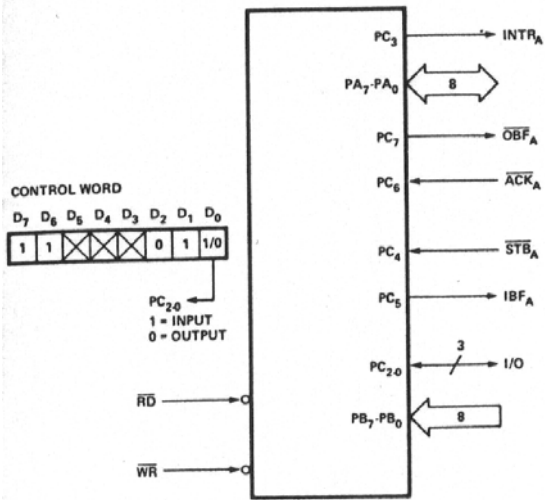

MODE 2 AND MODE 0 (OUTPUT)

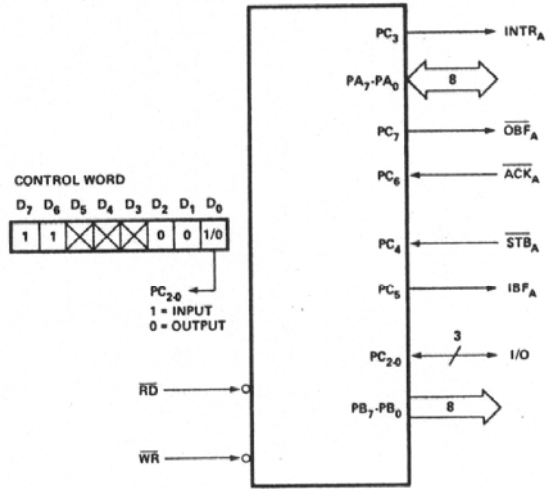

MODE 2 AND MODE 1 (OUTPUT)

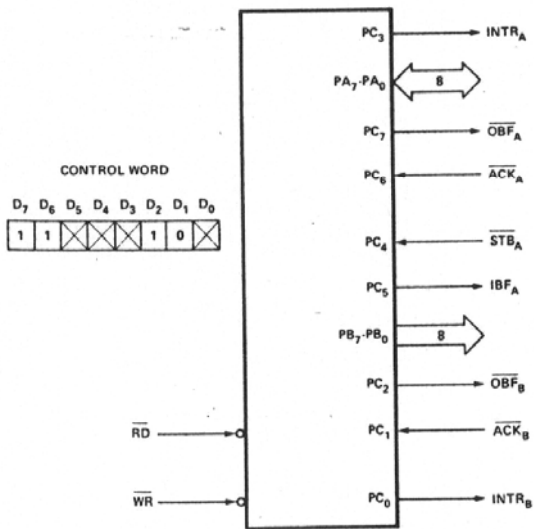

MODE 2 AND MODE 1 (INPUT)

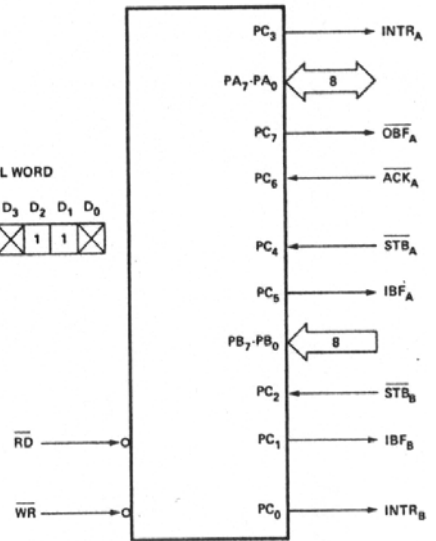

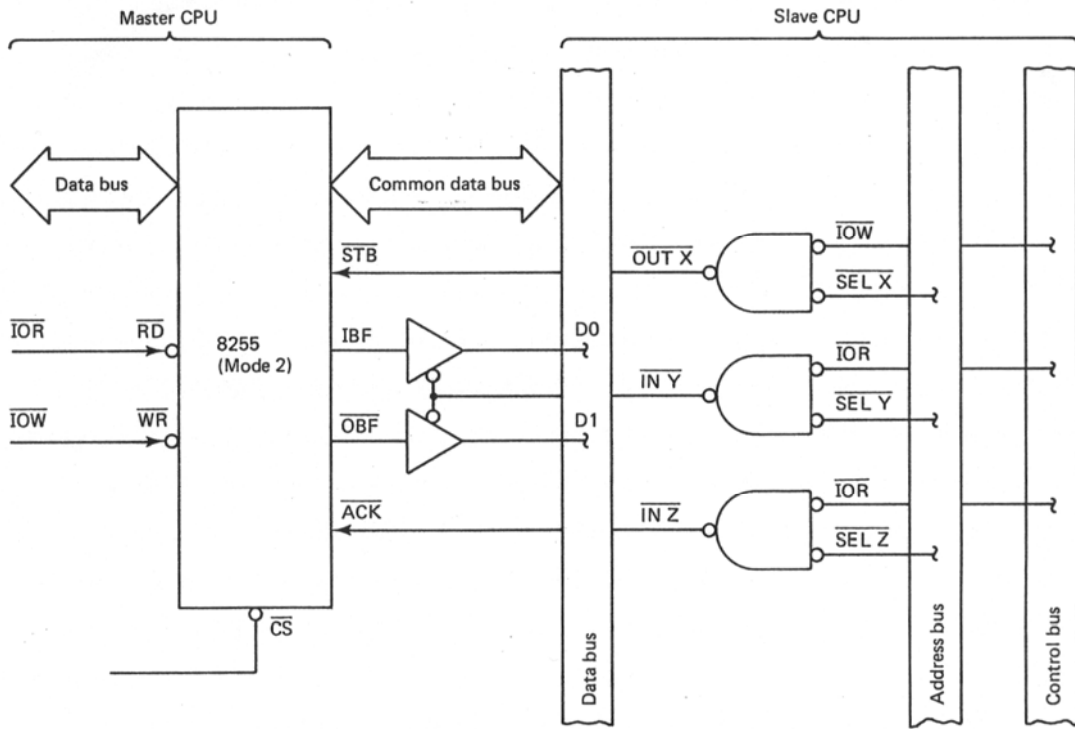

## 9.6. 8251 Seri Giriş/Çıkış Birimi

### 9.6.1. Uç Ayrıntıları

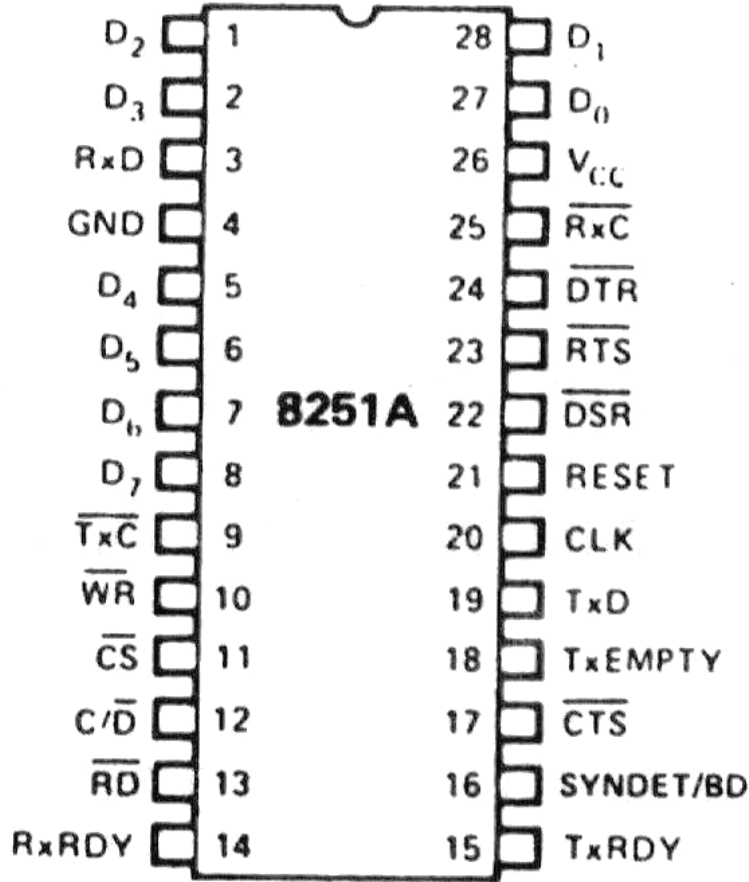

D0-D7	8-Bit Veri Yolu
C/D	İç yazmaç seçim giriş ucu
CS	Yonga Seçim giriş ucu
RD	Okuma kontrol giriş ucu
WR	Yazma kontrol giriş ucu
RESET	Yeniden başlat giriş ucu
CLK	Sistem saati giriş ucu
RxD	Seri veri alma giriş ucu
TxD	Seri veri gönderme çıkış ucu
RxC	Seri veri alma saati giriş ucu
TxC	Seri veri gönderme saati giriş ucu
RxRDY	Alınan veri mikroişlemciye giriş için hazır çıkış ucu
TxRDY	Gönderici mikroişlemciden gelen veri için hazır çıkış ucu
TxEMPTY	Gönderici boş çıkış ucu
SYNDET/BD	Uygunlaştırıcı / Kırılma algılandı
RTS	Gönderme isteği çıkış ucu
CTS	Göndermeyi temizle giriş ucu
DSR	Veri kümesi hazır giriş ucu
DTR	Veri terminali hazır çıkış ucu
VCC, GND	Besleme uçları

### 9.6.2. 8251 Seri Giriş/Çıkış Birimi İç Blok Diyagramı

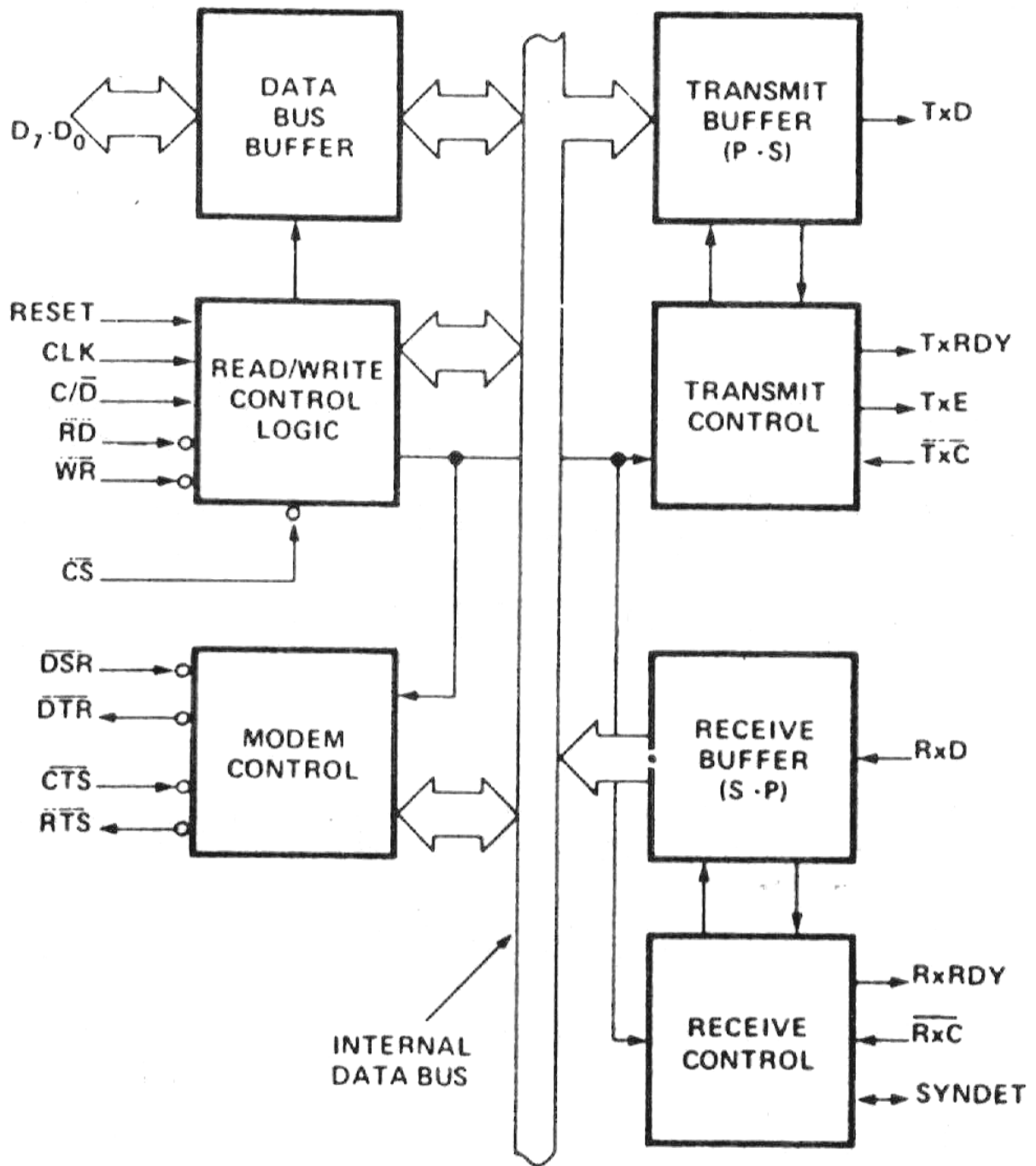

### 9.7. 8251 Seri Giriş/Çıkış Birimi Uygulama Devresi

